

# INSTALLATION GUIDE

# AMP RESEARCH Power Step

MADE IN USA

## APPLICATION

		AMP Part #
Chevrolet Silverado 2500/3500 / GMC Sierra 2500/3500 - Ext. Cab *	2007 - 2014	75126-01A
Chevrolet Silverado 2500/3500 / GMC Sierra 2500/3500 - Crew Cab	2007 - 2014	75126-01A
Chevrolet Silverado 1500 / GMC Sierra 1500 - Ext. Cab*	2007 - 2013	75126-01A
Chevrolet Silverado 1500 / GMC Sierra 1500 - Crew Cab	2007 - 2013	75126-01A
Chevrolet Silverado 1500 / GMC Sierra 1500 - Hybrid	2009 - 2013	75126-01A

**(Excludes all 2011-up models with Diesel engine.)**

\* Modification required to running board assembly. See Item 1 on page 3.

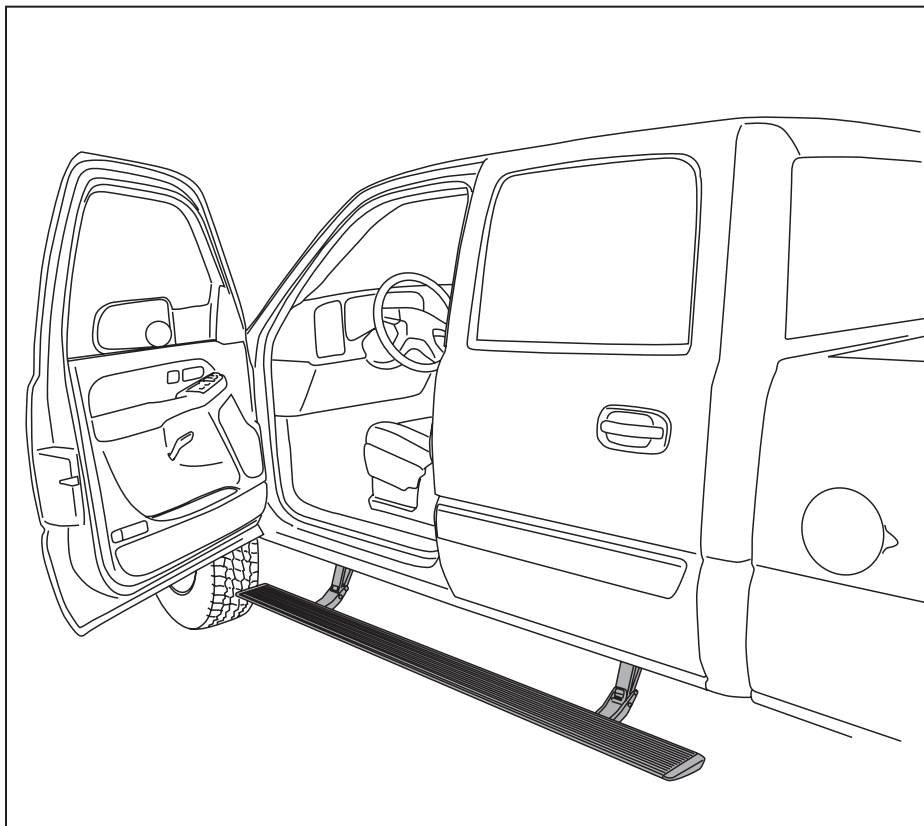

## INSTALLATION TIME

**3-5 Hours**

Professional installation recommended

## SKILL LEVEL



4= Experienced

## TOOLS REQUIRED

- Safety goggles
- Measuring tape
- Flat blade screwdriver
- Power Drill
- 9/32" drill bit
- 13 mm socket
- 10 mm socket
- Ratchet wrench and extension
- 13mm end wrench
- Wire crimpers
- Wire stripper / cutter
- 3/16" hex key wrench (allen wrench)
- 5mm hex key wrench (allen wrench)
- 4mm hex key wrench ( allen wrench )
- Electrical tape
- Weather proof caulking (silicone sealer)
- Silicone spray

## WARRANTY

**5-Year Limited Warranty**

AMP RESEARCH TECH SUPPORT 1-888-983-2204 (Press 2) Monday - Friday, 6:00 AM - 5:00 PM PST

Invented, engineered and manufactured exclusively by AMP Research in the USA. May be covered by one of the following patents: 6,641,158; 6,830,257; 6,834,875; 6,938,909; 7,055,839; 7,380,807; 7,398,985; 7,584,975 ©2012 AMP Research. All rights reserved. Printed in USA.

## INSTALLATION GUIDE

### Attaching motor to Linkage assembly

The motors must be attached to the Linkage assemblies before continuing the installation process.

#### EXPLODED VIEW

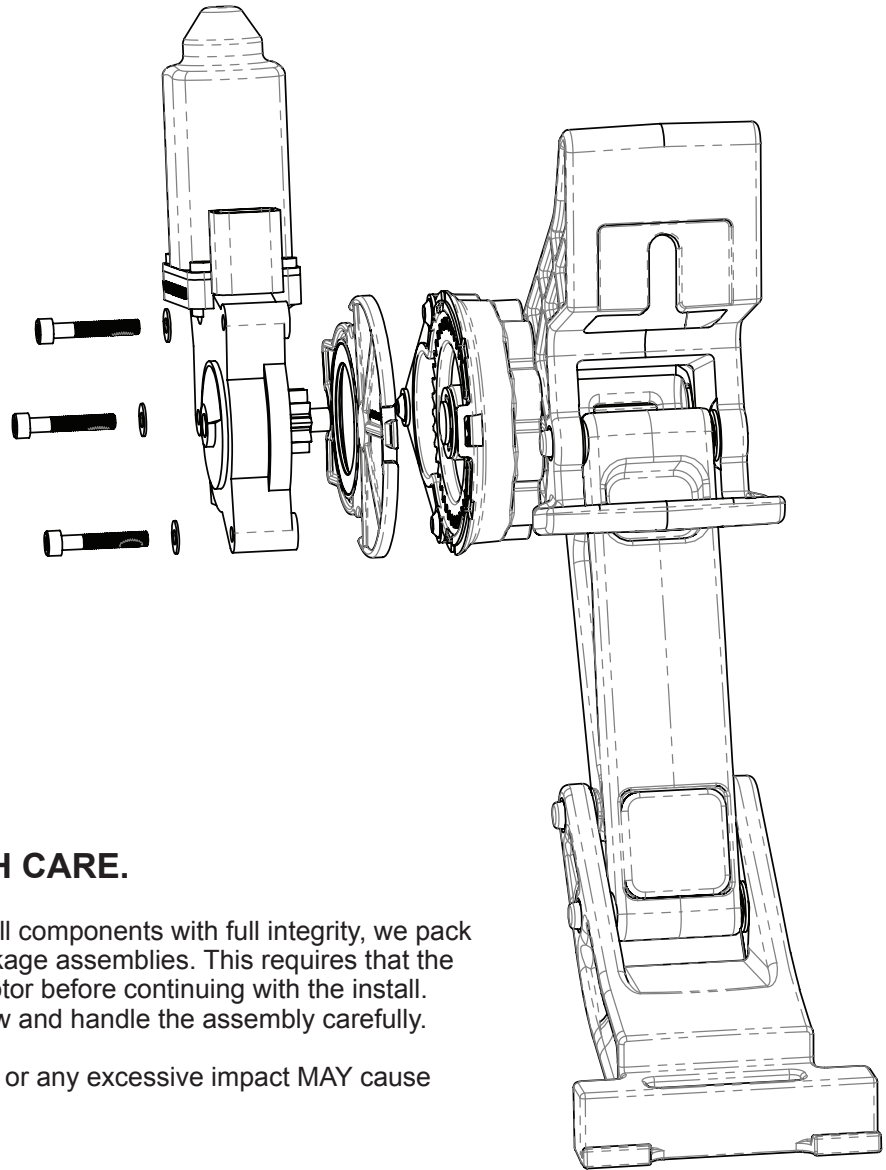

- Motor
- Gear Cover
- Socket cap screw
- Washer

#### CAUTION: HANDLE WITH CARE.

To ensure our customers receive all components with full integrity, we pack the motors separate from their Linkage assemblies. This requires that the installer position and fasten the motor before continuing with the install. Please follow the instructions below and handle the assembly carefully.

CAUTION: Dropping the assembly or any excessive impact MAY cause damage to the motor.

#### Instructions:

1. Position the gear cover in place as shown if not already in place.
2. Seat motor into position on the three mounting bosses. This may require an adjustment of the gear by moving the swing arms.
3. After seating into place, fasten the motor with the three motor mount screws with 4mm Hex Head. Tighten screws to 36 in-lbs (4N-m). **Do not over torque.**

**Note: Some Applications require modification.**

**Application**

Crew Cab  
Extended Cab

**Cut Length**

79" (No Modification Required)  
72" (Trim 7")

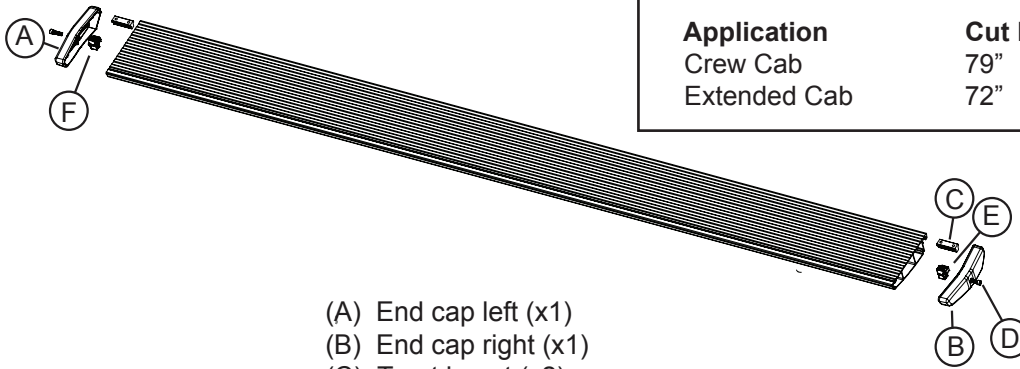

- (A) End cap left (x1)
- (B) End cap right (x1)
- (C) T-nut insert (x2)
- (D) Socket cap screw (x2)
- (E) End cap wedge right (x1)
- (F) End cap wedge left (x1)

1 x2

Running board assembly

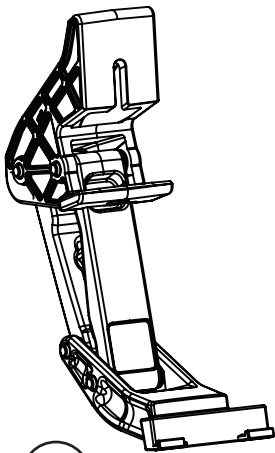

2 x2

Idler Linkage assembly

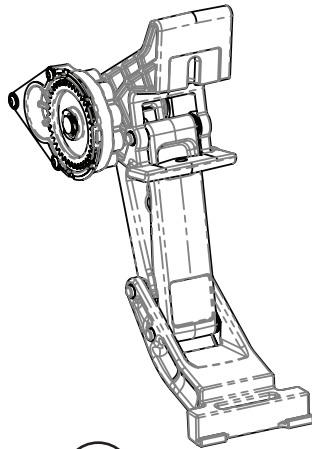

3 x2

Motor Linkage assembly

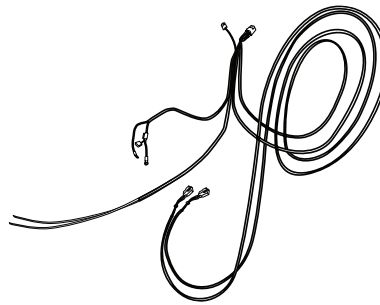

4

Wire harness

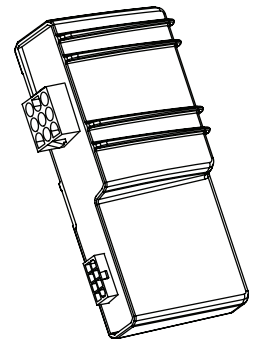

5

Controller



USED ON SILVERADO  
AND SIERRA  
HEAVY DUTY ONLY.

6a

Cable Bracket

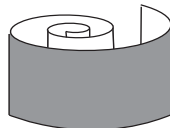

6b

Rubber



USED ON SILVERADO  
AND SIERRA  
HEAVY DUTY ONLY.

7

Brake Cable Ring

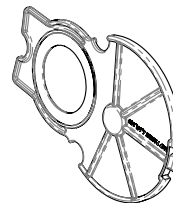

8 x2

Gear Cover

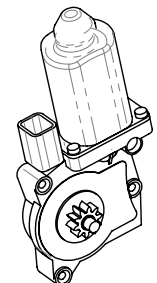

9 x2

Motor

AMP RESEARCH POWERSTEP™ – CHEVROLET / GMC

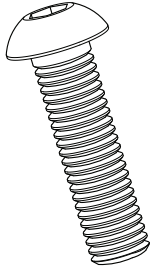

10 x4  
Socket Cap Screw

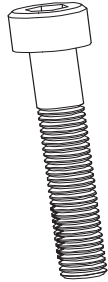

11 x6  
M5 Socket Cap Screw

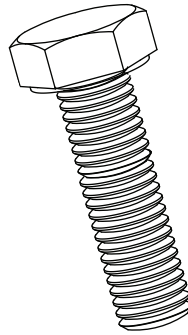

12 x5  
Hex Bolt

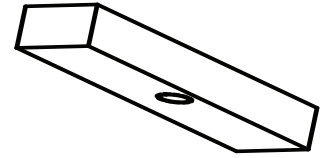

13 x4  
Threaded clamping plate



14 x6  
M5 Washer

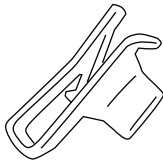

15 x4  
U-nut

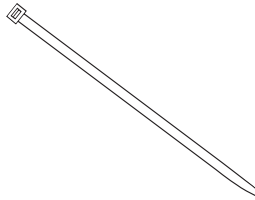

16 x20  
Cable tie (7")

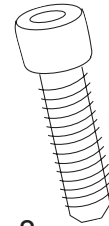

17 x8  
Socket Cap Screw

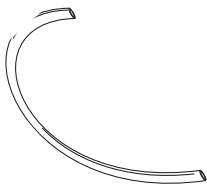

18  
Tubing (Installation Tool)

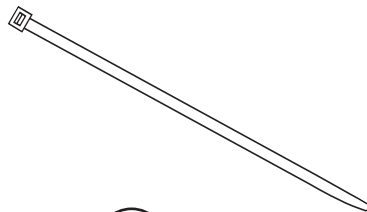

19 x2  
Cable tie (11")



20 x4  
Posi-Tap™

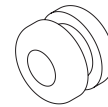

21  
Grommet

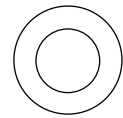

22 x4  
Washer



23  
Nylock Nut

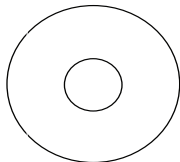

24 x2  
Washer

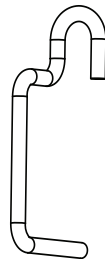

25  
Cable Bracket



26  
Spacer

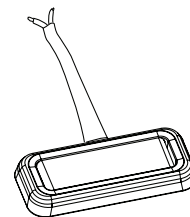

27 x4  
LED Lamp



28 x8  
Butt Connector

Steps 2-3 for **2007-2010 HD 2500 and 3500 only!** For all other vehicles skip to Step 4.

Short Bed: Step 2 only

Long Bed: Steps 2 and 3.

Remove forward most parking brake cable guide and replace with new guide (6).

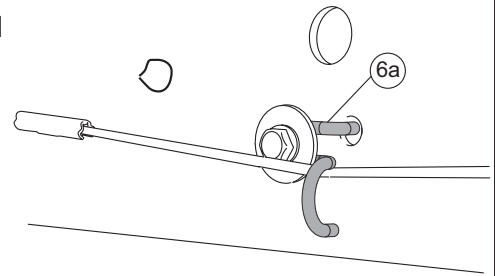

On some models that do not utilize this guide rubber tape is included. Wrap tape around bracket.

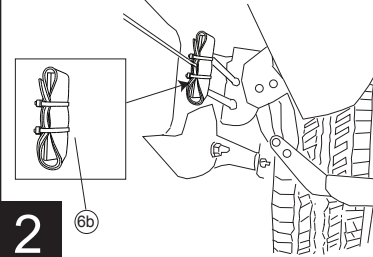

1

2

Install driver side **Idler Linkage** in first sheetmetal tab / hole from front.

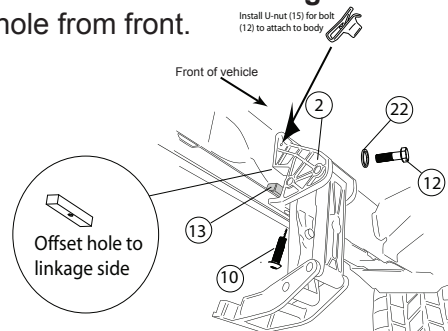

Install threaded clamping plate (13) on top of pinch weld and thread fastener (10) into clamping plate and finger tighten. Install fastener (12), finger tighten only. Next tighten fastener (10) to 16 ft-lbs. (22N m). Next torque fastener (12) to 16 ft-lbs. (22N m)

4

**Extended Cab Trucks ONLY**

Install passenger side **Motor Linkage** Position spacer (26) between body pinch weld and linkage mounting flange (3) as shown.

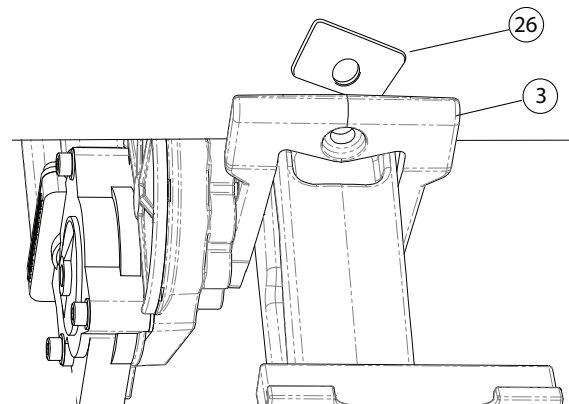

6

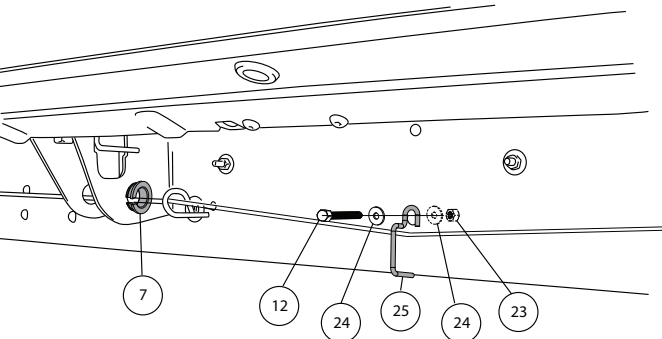

Install nut and washer on back side of frame rail

Install plastic brake cable guide (7) in rear of middle body mount. Install new parking brake cable guide (25) in existing frame hole as shown.

3

Install driver side **Motor Linkage** in fourth sheetmetal tab / hole from front. Linkage will then clear parking brake cable. Crew Cab: repeat linkage installation on passenger side. Extended Cab: go to step 6.

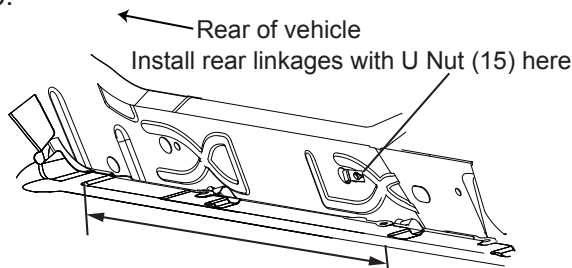

**Crew Cab**- Approx 26 1/4" from back of cab  
**Extended Cab**- Approx 11" from back of cab

5

Repeat linkage installation on passenger side.

Slide mounting T-nut into position, aligning the end of the board with the rear edge of the back door. Mount board and tighten fasteners to 10 ft-lbs. Insure linkages are squared to body prior to torquing fasteners.

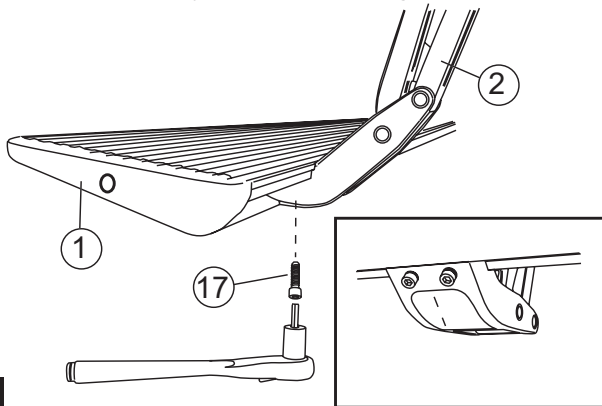

7

Tighten fastener (12) from from step 4 to 16 ft-lbs. (22 N m).

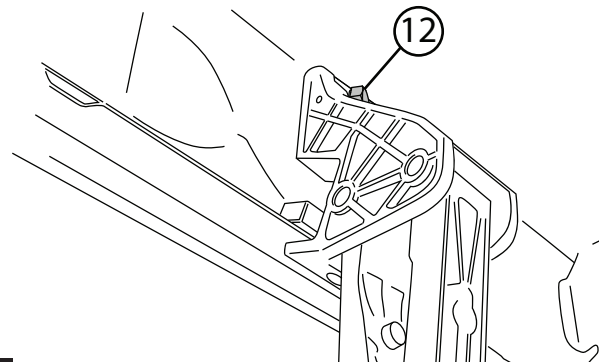

8

Using the two 11" cable ties, mount controller to support arm next to battery. (Behind support arm on diesel engine) **On Hybrid models: Mount controller on drivers side of engine compartment.**

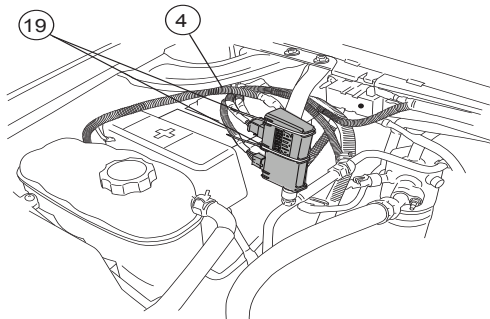

Plug in wire harness.  
(Ensure that locking tabs engage.)

9

Remove power fuse. Attach power lead (RED wire) to positive pole on the battery.

**CAUTION:** Do not ground wrench when engaged with nut.

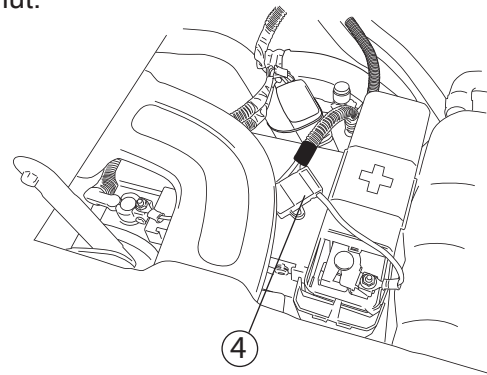

Attach ground lead to negative battery pole.

10

### GAS ENGINE WIRE ROUTING

Route long end of wire harness above engine and down through drivers side wheel well. Zip tie harness to cowling clips on fire wall. Route short end down passengers side. **On Hybrid models: Long end of wires will be routed down through passenger side wheel well and short end down drivers side.**

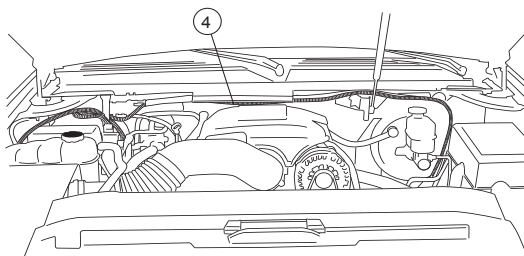

Secure with zip ties.

11

### DIESEL ENGINE WIRE ROUTING

Route long end of wire harness under intake and along factory engine harness to driver side wheel well. Route short end down passengers side.

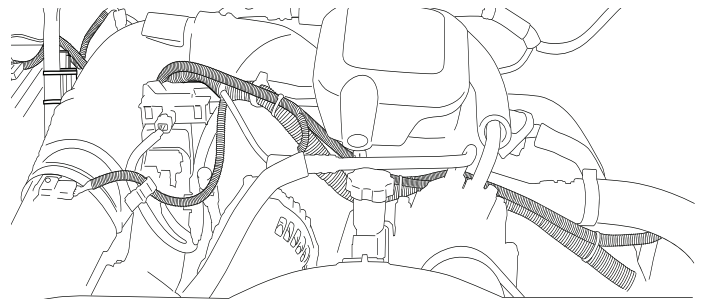

Secure with zip ties.

12

**IMPORTANT: Steps 16 and 17 are for Crew Cab trucks only.**  
**(Light Blue and Green wires are only used with Crew Cab trucks.)**

Route wire harness along the frame and back towards rear linkage. Secure with zip ties. Poke hole through rubber grommet near front door on underside of floor panel with small phillips screwdriver. Push both wires through hole. (See Step 14 for passenger side notes.)

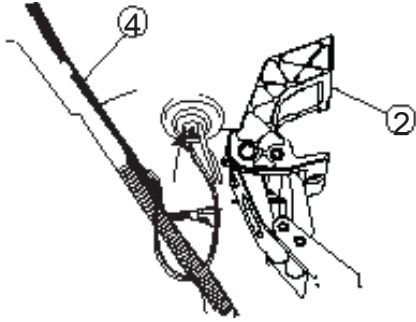

13

Pop off the threshold cover with screwdriver and remove the kick panel. Repeat step on passenger side.

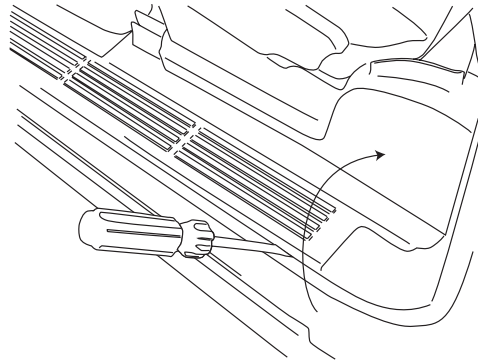

14

Pull up the carpet and thread both wires through the floor panel (same steps on passenger side EXCEPT drill 9/32" hole in metal and add rubber grommet).

**For all vehicles except Crew Cabs skip to step 18.**

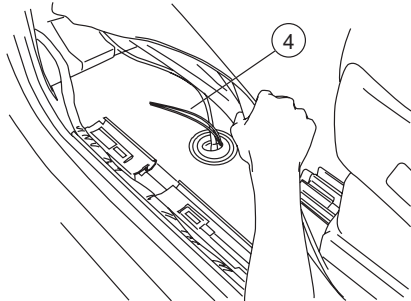

Seal holes with silicone glue and cover with tape so carpet does not stick to glue.

15

**Crew Cab Only** - Carefully remove wire wrap and find LIGHT BLUE wire with BLACK STRIPE. On passenger side find GREEN wire with BLACK STRIPE. The wire is located rear of the "T" junction where wires cross under the front seat.

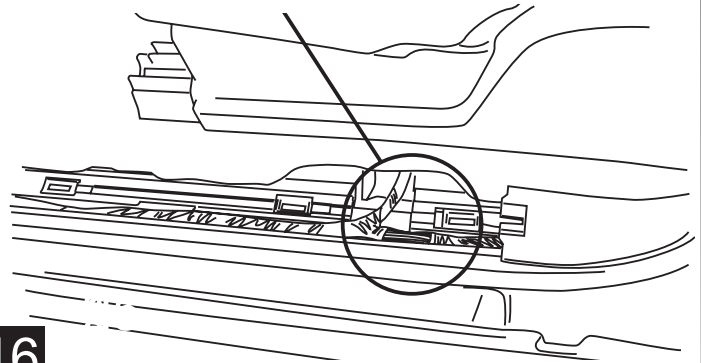

16

**Crew Cab Only.** Using supplied Posi-Tap™ connector, splice shorter trigger wire into wire found in Step 16. Otherwise tape off short wire.

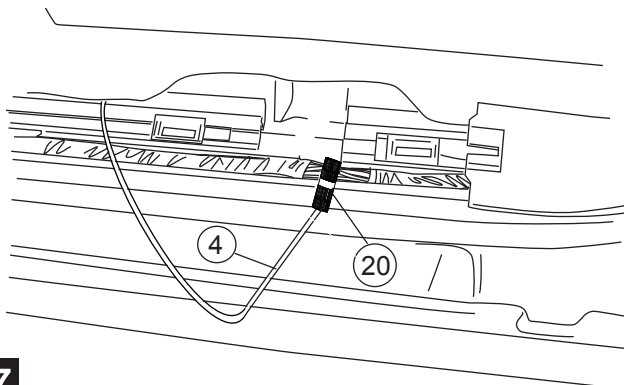

17

Posi-Tap™ instructions

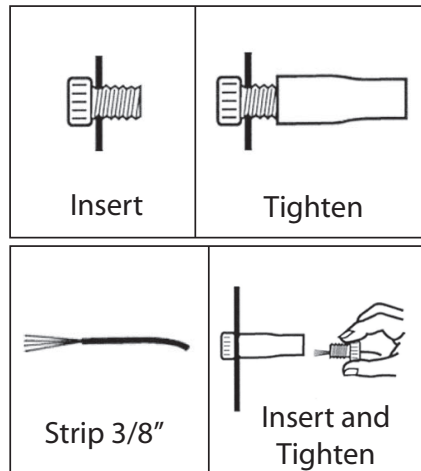

18

For model years 2007-2010 locate and inspect the Body Control Module above the brake pedal under the dashboard. The BCM is the only module with a pink connector. Check to see if the front door ajar signal wires are present in the pink connector: Grey/Black, Tan/White. If you do not see these wires the front door panels must be removed.

Location of Body Control Module

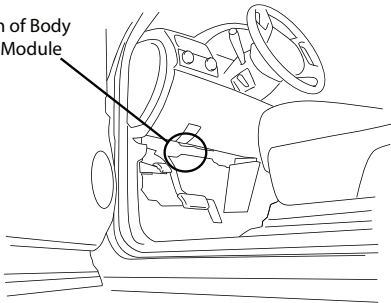

Vehicles that do not have the front door ajar signal wires in the pink connector of the BCM must have the front door panels removed in order to access the front door ajar signal wires. **For these and all Hybrid models Go to step 22.**

19

20

Remove driver side kick panel and open the loom wrapped in grey or black tape to access the Grey / Black stripe wire. In the passenger side kick panel the loom wrapped in green or black tape will have a Tan / White stripe wire. Connect Power Step Grey / Black and Tan / White wires to like colored factory. Go to step 29.

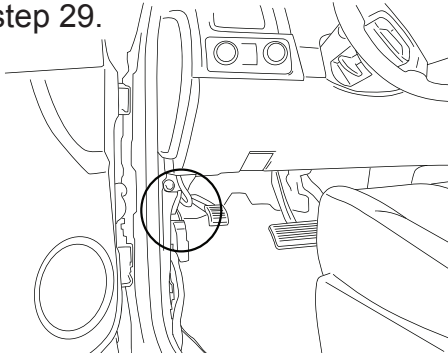

Remove plastic trim on door near mirror attachment. Then carefully pry up window/ door lock switch plate.

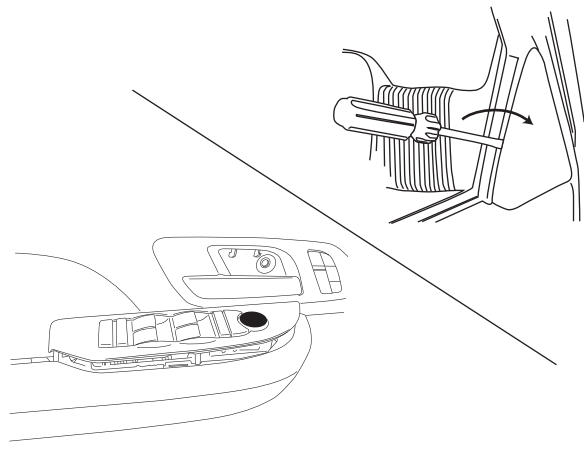

21

22

Remove all plugs from switchplate

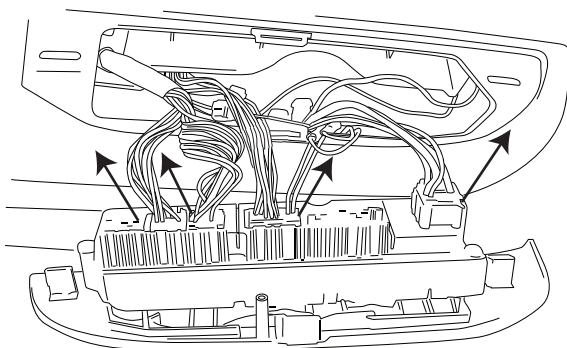

To remove door panel, first pry back tab on door lock to remove then pry off plastic covers by handle and door latch. Remove the 3 door bolts and then remove door panel by prying loose all panel fasteners.

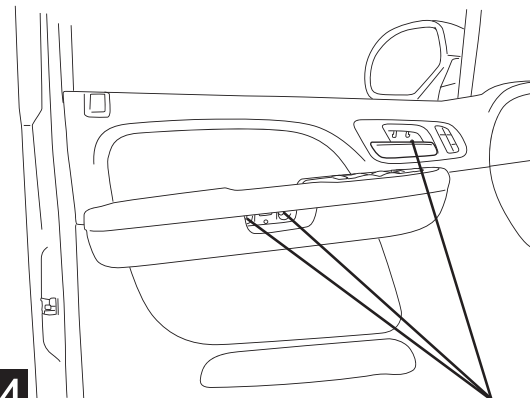

23

24



Remove door latch cable from door panel.

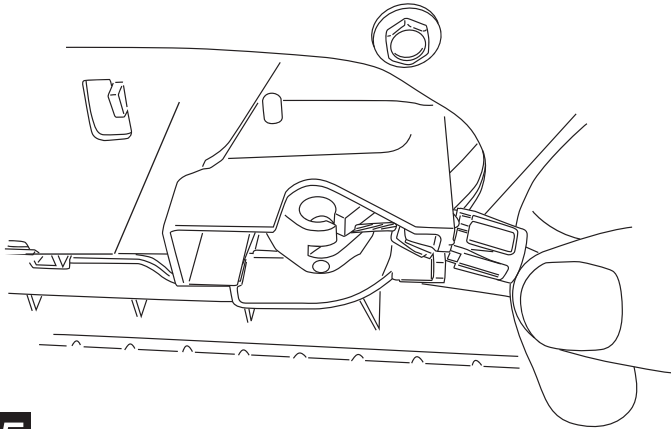

25

Pull back the door weather guard, unbolt speaker and unplug. Thread plastic tube through accordion.

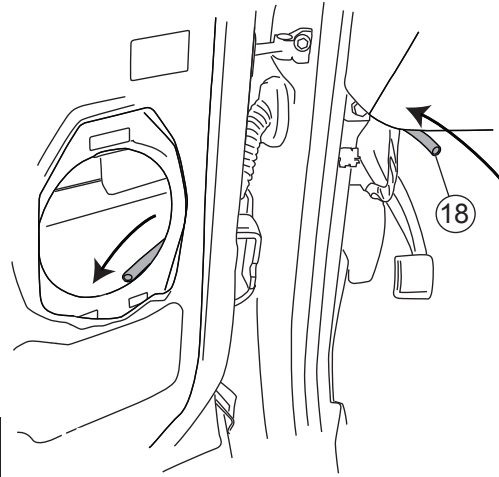

26

Feed longer wire of Step 15 through tube into door and pull out plastic tube on door side. Route wire along harness to switchplate.

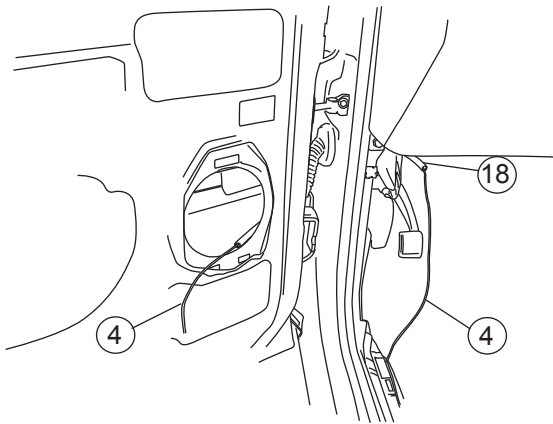

27

**For 2007-2009 Models:**

Locate the brown plug in doors and using supplied Posi-Tap™ connector, splice into trigger wire.

Drivers side: Grey / Black wire

Passengers side: Tan / White wire

**Note: On Hybrid models trigger wire colors will not match up because wire harness is flipped.**

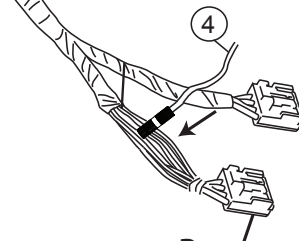

Brown plug

28

Reassemble door and replace plugs. Plugs must be replaced for Power Step to operate.

**For 2010-Current models:**

Locate loom that runs across the top of the door panel. Carefully remove wire wrap and locate the following wires on either side. **Drivers side:** Grey / Black wire **Passenger side:** Tan / White wire **Caution:** Zip tie trigger wires to avoid being hung up in window linkage.

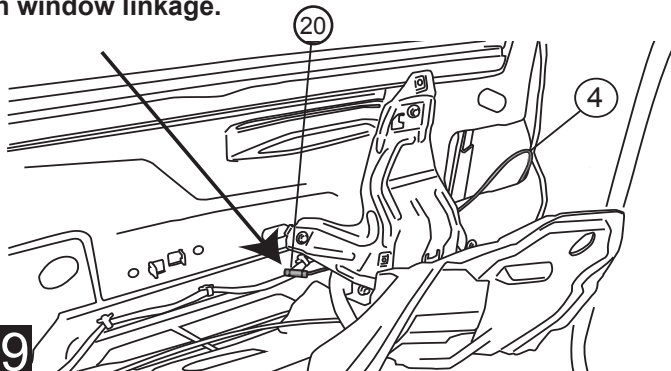

29

On each side of the vehicle measure from the front edge of door line on the pinch weld to the specified lengths below. Measure at 22" for front LED Light and 65" for rear LED Light.

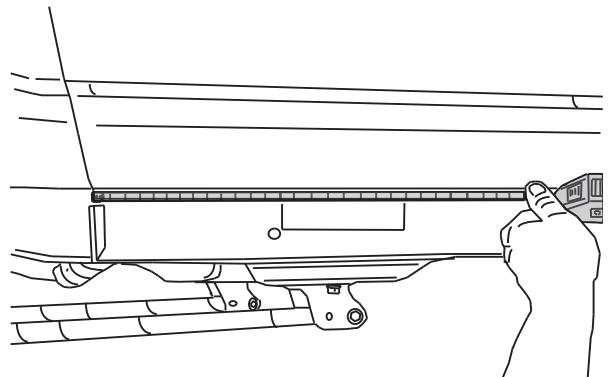

30

## AMP RESEARCH POWERSTEP™ – CHEVROLET / GMC

Affix lamp to rocker panel surface. Make sure the lamp is affixed to a clean, flat surface. There is a step down midway across the surface. Affix lamp just outside of step down.

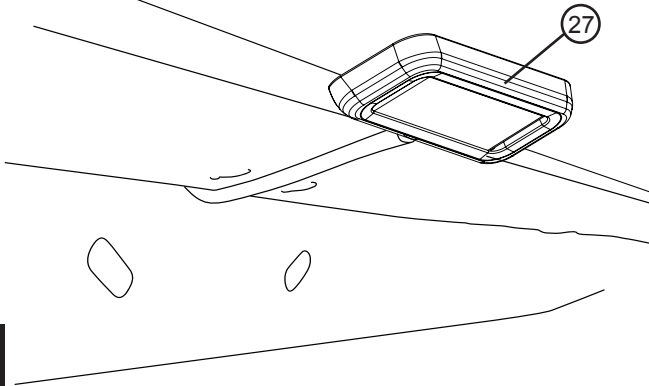

31

Using supplied butt connectors, connect the lamp wires. Red to Red, Black to Black. Close and wrap conduit with electrical tape. Secure all loose wires with cable ties. Pull lamp wires upward to avoid any wire snagging.

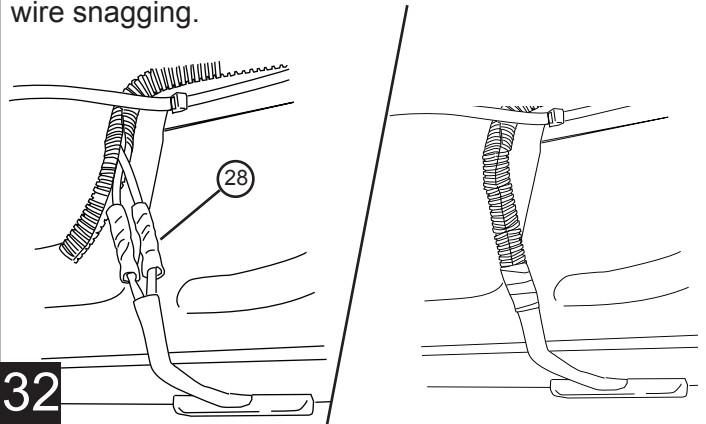

32

Reinstall fuse. Check that all doors activate the Power Step and the LED Lights work when doors open and close. Reinstall any remaining trim panels.

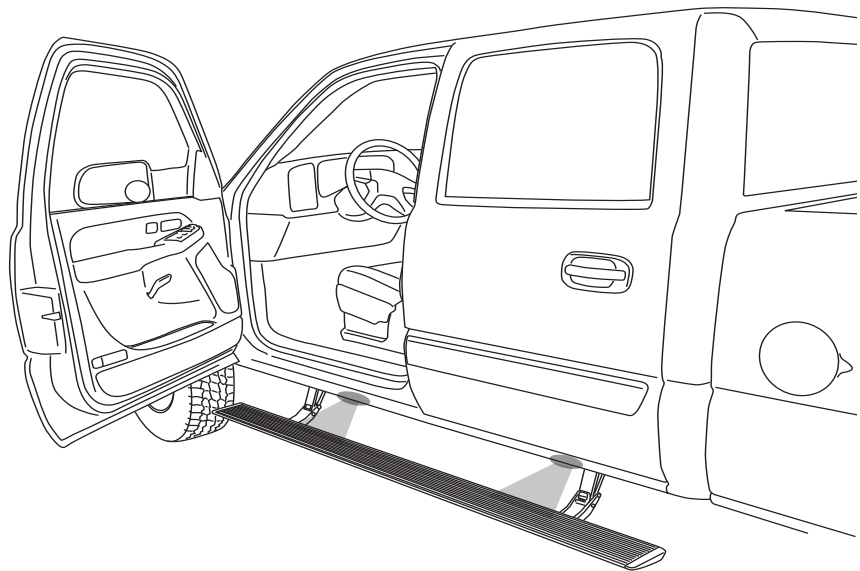
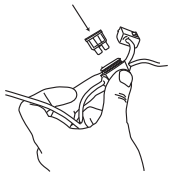

### FINAL SYSTEM CHECK

Check that all doors activate the PowerStep and the LED lights work when doors open and close.

**NORMAL OPERATION:** When the doors open, PowerStep automatically deploys from under the vehicle.

When the doors are closed, PowerStep will automatically return to the stowed/retracted position. **Note that there is a 2-second delay before the PowerStep returns to the stowed/retracted position.**

**CORRECT OPERATION OF LIGHTS:** All four lamps will illuminate upon opening any door of vehicle. Lamps will stay on until restowing of both Power Steps or until 5 minutes has expired with the doors open. When the lights timeout after 5 minutes, they can be reilluminated by closing and opening any door of vehicle.

33

**POWER-DEPLOYABLE RUNNING BOARDS OPERATION:** AMP Research PowerStep running boards automatically move when the doors are opened to assist entering and exiting the vehicle.

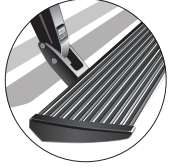

**Automatic power deploy:**

The running boards will extend down and out when the doors are opened.

**Automatic power stow:**

The running boards will return to the stowed position when the doors are closed. There will be a 2-second delay before the running boards move to the stowed position.

**Automatic stop:**

If an object is in the way of the moving running board, the running board will automatically stop. To reset, clear any obstruction, then simply open and close the door to resume normal operation.



**Manually set in the deployed (OUT) position for access to the roof:**

The running boards can be manually set in the deployed position by firmly holding the step down with your foot while at the same time closing the door. To resume normal operation, open and close the door.

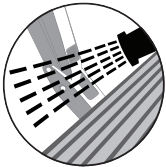

**Maintenance:** In adverse conditions, debris such as mud, dirt, and salt may become trapped in the running board mechanism, possibly leading to unwanted noise. If this occurs, manually set the running boards to the deployed position and flush the front and rear hinge arms with a high-pressure car wash wand. Avoid spraying the motors directly. After washing, apply silicone spray lubricant to the hinge pivot pins. Do not apply silicone, wax or protectants like Armor All® to the running board stepping surface.

**Caution!** Keep hands away when the running board is in motion.

## 5-YEAR LIMITED WARRANTY

AMP RESEARCH warrants this product to be free from defects in material and workmanship for FIVE (5) YEARS FROM DATE OF PURCHASE, provided there has been normal use and proper maintenance. This warranty applies to the original purchaser only. All remedies under this warranty are limited to the repair replacement of the product itself, or the repair or replacement of any component part thereof, found by the factory to be defective within the time period specified. The decision to repair or replace is wholly within the discretion of the manufacturer.

This warranty specifically excludes labor. If you have a warranty claim, first you must call our factory at the number below for instructions. You must retain proof of purchase and submit a copy with any items returned for warranty work. Upon completion of warranty work, if any, we will return the repaired or replaced item or items to you freight prepaid. Damage to our products caused by accidents, fire, vandalism, negligence, misinstallation, misuse, Acts of God, or by defective parts not manufactured by us, is not covered under this warranty.

ANY IMPLIED WARRANTIES OF MERCHANTABILITY AND/OR FITNESS FOR A PARTICULAR PURPOSE CREATED HEREBY ARE LIMITED IN DURATION TO THE SAME DURATION AND SCOPE AS THE EXPRESS WRITTEN WARRANTY. OUR COMPANY SHALL NOT BE LIABLE FOR ANY INCIDENTAL OR CONSEQUENTIAL DAMAGE.

Some states do not allow limitations on how long an implied warranty lasts, or the exclusion or limitation of incidental or consequential damages, so the above limitations or exclusions may not apply to you. This warranty gives you specific legal rights, and you may also have other rights that vary from state to state.

**FOR WARRANTY ISSUES WITH THIS PRODUCT PLEASE CALL AMP RESEARCH CUSTOMER SERVICE 1-888-983-2204**

## WARNING

Be sure to read and precisely follow the provided instructions when installing this product. Failure to do so could place the vehicle occupants in a potentially dangerous situation. After installing or reinstalling, re-check to insure that the product is properly installed.