

Installation Manual

VERSION
FRANÇAISE



AIR SPRING KIT

Chevy Silverado/GMC Sierra 2500/3500 (2WD/4WD)* (SRW/DRW)
with or without 5th Wheel Hitch

Use the most advanced air springs on the market to eliminate your vehicle's sag, sway and bottoming out. This heavy duty air suspension kit levels your truck's stance while providing added support for an overall smooth and safe ride.

* See application guide for proper fitment.

L6502_REV8_02.22.2023



WARNING: This product can expose you to the chemical Hexavalent Chromate, which is known to the State of California to cause cancer and birth defects or other reproductive harm. *For more information go to www.P65Warnings.ca.gov*

IMPORTANT

This air suspension kit will not increase the GVWR (*Gross Vehicle Weight Rating*), as the GVWR is determined by the vehicle manufacturer. **Do not exceed the maximum capacity listed by the vehicle manufacturer.**

PLEASE NOTE: *The air bag must have clearance between itself and the surrounding components to prevent any contact when bag is inflated or compressed. Trimming off excess bolt length is also required to ensure no contact with the bag or other suspension components can be made once installed.*

Safety Warnings!

- ❗ Serious personal injury or death may result from an air spring failure or accident due to improper installation or air spring pressure operation or maintenance. Please read and abide the instructions, safety recommendations and maintenance suggestions throughout this manual.
- ❗ Inflating an unsecured air spring is dangerous. If it bursts, it could be hurled into the air with explosive force resulting in serious personal injury or death. Never inflate an air spring unless it is secured to the vehicle.
- ❗ Removing and replacing air springs can be dangerous. This is only a job for a qualified service professional. Never perform air spring service procedures without proper training, tools, and equipment.

KIT CONTENTS

Reference the kit explosion diagram on the following page for part assembly.

KIT CONTENTS			QTY	PART #	REQUIRED TOOLS
A	Air Spring	2	HP10000	<ul style="list-style-type: none"> • Hoist or Floor Jack • Safety Stands • Safety Glasses • Torque Wrench • Standard Combination Wrenches • Ratchet • Metric & Standard Sockets • Hose Cutter (included) or Sharp Utility Knife • Pipe Thread Sealant • Spray Bottle with Dish Soap/Water • Air Compressor/Compressed Air Source (to test/fill air springs) 	
B	Roll Plate	4	HP10054		
C	Upper Bracket (Driver Side) <i>(not shown)</i>	1	HP1620		
D	Upper Bracket (Passenger Side)	1	HP1621		
E	Lower Bracket	2	HP1622		
F	Relocation Bracket	2	HP1588		
G	Round U-Bolt, 4" x 5.5"	2	HP1589		
H	Square U-Bolt, 4.25" x 6.5"	2	HP1331		
I	Axle Strap	2	HP0128		
J	Countersunk Bolt, 3/8" - 24 x 3/4"	8	HP1008		
K	Flange Bolt, M8 x 1.25 x 25mm	2	HP1430		
L	Nylock Nut, 3/8" - 16	12	HP1000		
M	Carriage Bolt, 3/8" - 16 x 3.5"	4	HP1332		
N	Serrated Flange Nut 3/8" - 16	2	HP1338		
O	Flat Washer, 3/8"	12	C18006		
P	Heat Shield <i>(not shown)</i>	1	HP0012		
Q	Worm Gear Ring Clamp <i>(not shown)</i>	2	HP1001		
R	90° Swivel Air Fitting	2	HP1100		
S	Air Line Assembly <i>(not shown)</i>	1	HP1344		
T	Tie Straps <i>(not shown)</i>	6	C11618-8		

Please make sure all the items shown in this explosion diagram are provided in your kit before starting the installation.

PASSENGER SIDE ASSEMBLY SHOWN:

THREAD FITTING INTO AIR SPRING FINGER TIGHT, PLUS AN ADDITIONAL 1.5 TURNS.
SOME FITTINGS HAVE SEALANT PREAPPLIED ON THREADS. IF THREADS HAVE NO VISIBLE COATING, APPLY THREAD SEALANT OR TEFLON TAPE.

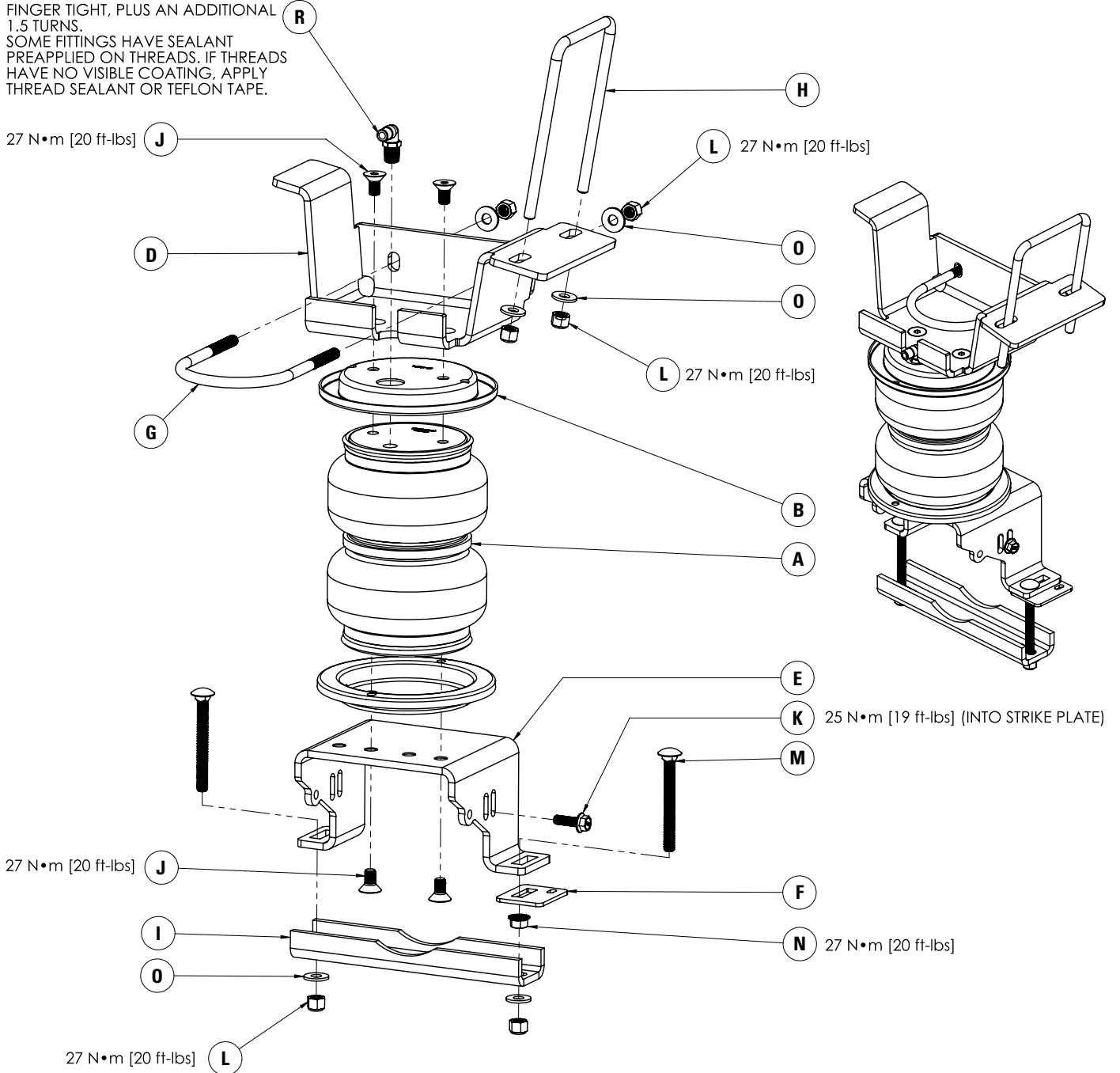

BEFORE STARTING THE INSTALLATION:

1. Ensure the application information is correct for the make, model and year of the vehicle you are installing the kit on.
2. Some vehicles are equipped with a rear wheel brake proportioning valve. Check with the manufacturer before installing the air spring kit, as it may affect braking performance.
3. It is recommended to use a good quality anti-seize on all fasteners. This will reduce the chance of corrosion on the fasteners and will help facilitate removal, if required at a later date.

PLEASE NOTE:

This kit contains push-to-connect fittings; using scissors or wire cutters to cut the nylon airline will distort the line and cause the connection to leak. THE AIRLINE MUST BE CUT OFF SQUARELY WITH THE NYLON HOSE CUTTER PROVIDED IN THIS KIT OR A SHARP UTILITY KNIFE.

1 MEASURE STOCK RIDE HEIGHT

Park the vehicle on a level surface.

Using a measuring tape, measure the distance between the center of the wheel hub and the bottom of the fender well (as shown in Figure 1) this will give you your ride height.

Note the ride height for all four corners.

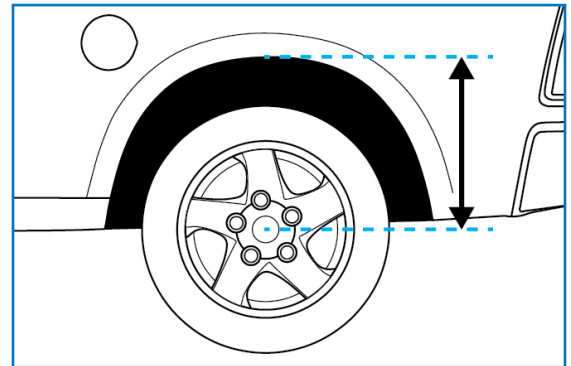

1

2 REMOVE REAR WHEELS

Place wheel chocks in front of and behind both front wheels.

Raise the rear of the truck high enough to remove both wheels and attain a comfortable working height.

Place two jack stands under rear axle (shown in Figure 2).

Lower the vehicle until the axle is supported by the jack stands.

Remove rear wheels.



2

3 REMOVE THE JOUNCE BUMPER

The jounce bumper assembly consists of a retaining cup and a rubber bumper.

Remove the two jounce bumpers (highlighted in Figure 3) by prying them out of the retaining cup. A pry bar or a large screwdriver is typically required.

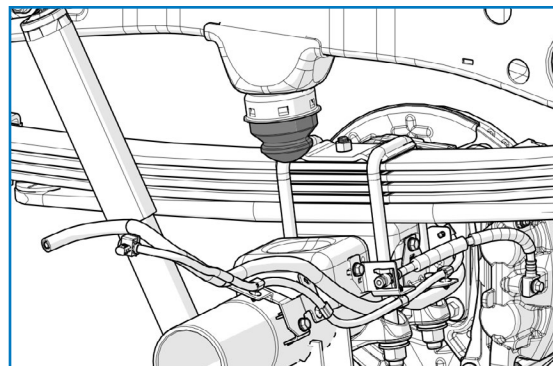

4 REMOVE THE ABS/BRAKE/E-BRAKE BRACKETS

Unclip the ABS wiring loom (highlighted in Figure 4) from the bracket holding it to the strike plate. Gently pull the wiring loom downwards away from the strike plate and let it hang freely.

Remove the M8 bolt (highlighted in Figure 4) holding the bracket to the strike plate using a 13 mm socket. Gently pull the bracket away from the strike plate and let the bracket hang freely. Discard bolt.

Repeat for opposite side.

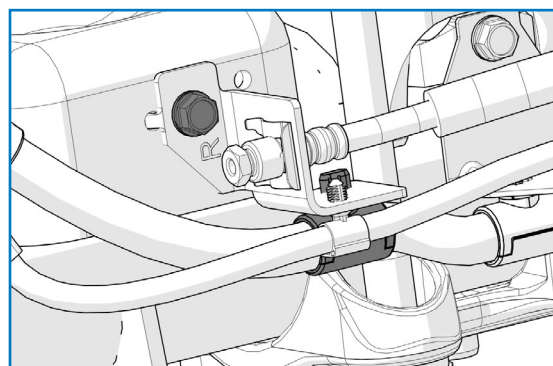

5 ASSEMBLE THE AIR SPRINGS AND BRACKETS

Assemble the air springs as shown in Figure 5A. Reference Figure 5B on following page for correct mounting hole assembly.

Set the roll plate over the over the bottom of the air spring. Then set the lower spring bracket onto the air spring. Ensure that the holes in the air spring, roll plate and lower bracket all line up.

Fasten the assembly together using two 3/8" – 24 countersunk cap screws. Torque the mounting hardware to 20 ft-lbs (27 N•m).

Turn the assembly over and set the roll plate on top of the air spring.

Fasten the swivel fitting into the top of the air spring. It is recommended to use Teflon tape or some form of thread sealant to prevent air leaks. Finger tighten the swivel fitting and turn an extra 1.5 turns to tighten.

Set the upper passenger spring bracket onto the air spring, ensuring that the holes in the air spring, roll plate and lower bracket all line up.

Fasten the assembly together using two 3/8" – 24 countersunk cap screws. Torque the mounting hardware to 20 ft-lbs (27 N•m).

Repeat the process using the upper driver spring bracket and alternate hole placement (see Figure 5B) to create the driver side assembly.

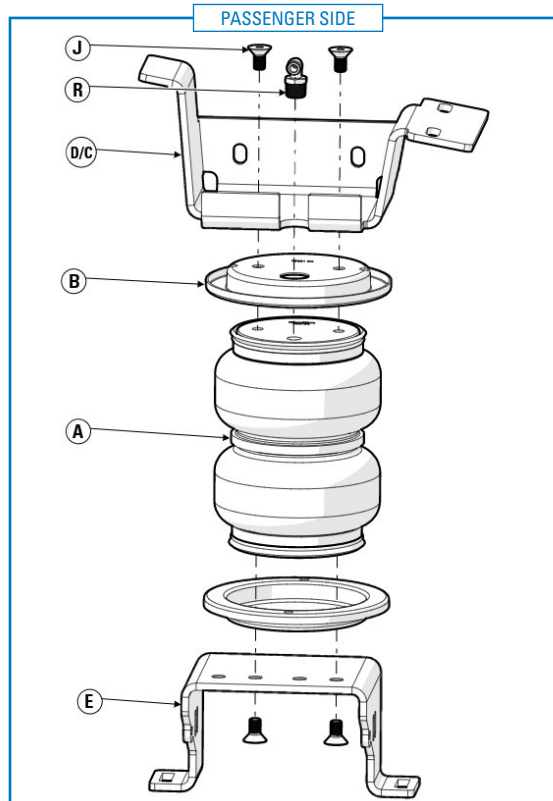

5A

6 INSTALL THE AIR SPRING ASSEMBLIES

Note: It may be necessary to raise the frame of the truck a few inches to allow more clearance to install the air spring assemblies.

Position the air spring assembly such that the lower bracket rests on the jounce bumper strike plate and the upper bracket nests around the jounce bumper (shown in Figure 6). The air fitting will be positioned on the inboard side of the frame.

Repeat for the opposite side

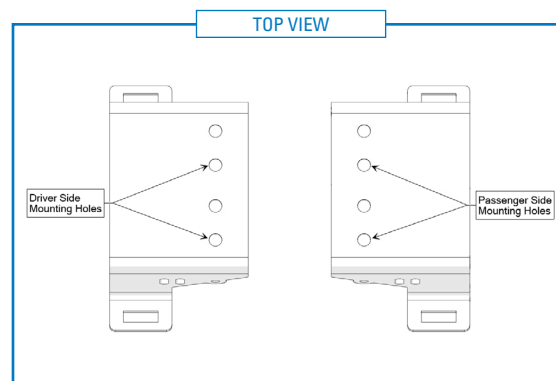

5B

7 INSTALL THE ABS RELOCATION BRACKET

Drop the carriage bolts into the slots on the lower bracket.

On the rearward side on the bracket, install the relocation bracket (shown in Figure 7). Ensure no wiring lines are pinched between the lower bracket and loom bracket. Secure using a flange nut but do not fully tighten yet.

Repeat for the other side.

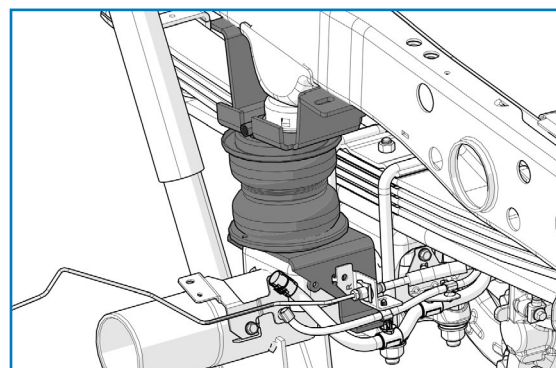

6

8 INSTALL THE AXLE CLAMP BAR

Position the axle strap on the axle such that the mounting holes are aligned with the carriage bolts in the lower bracket.

Secure the axle strap (as shown in Figure 8) using a flat washer and nylon locknut. Remove the slack by threading the on the nuts, but do not torque yet.

Align the air spring by adjusting the lower bracket on the strike plate so the slots in the lower bracket line up with the holes in the strike plate.

Torque the axle strap nuts to 20 ft-lbs (27 N•m).

Torque the relocation bracket flange nut to 20 ft-lbs (27 N•m).

Repeat for opposite side.

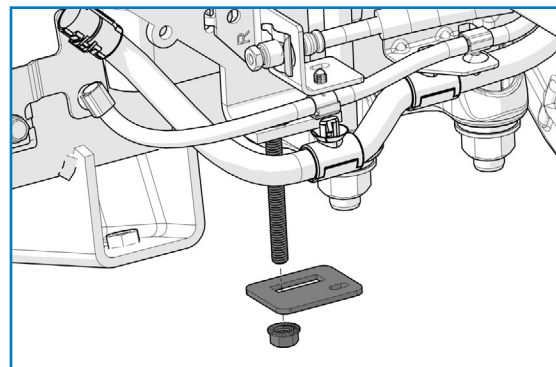

7

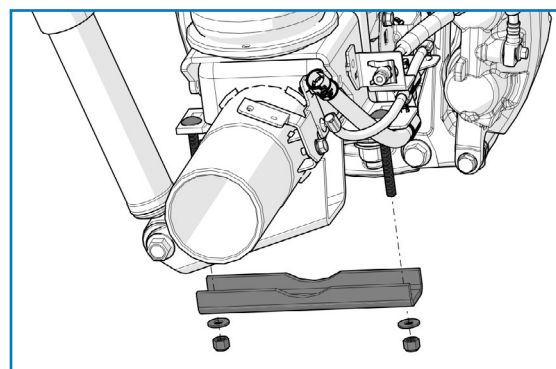

8

9 SECURE THE UPPER BRACKET

Install the square U-bolt around the frame of the vehicle and through the mounting holes in the upper bracket. Ensure no lines or wires are pinched between the U-bolt and the frame.

Install one flat washer and one nylon locknut on each end of the U-bolt (shown in Figure 9A). Remove the slack by threading the on the nuts, but do not torque yet.

Install the round U-bolt around the jounce bumper cup of the vehicle and through the side mounting slots in the upper bracket (shown in Figure 9B).

Install one flat washer and one nylon locknut on each end of the U-bolt (shown in Figure 9C).

Torque the round U-bolt nuts to 20 ft-lbs (27 N•m).

Torque the square U-bolt nuts to 20 ft-lbs (27 N•m).

Trim excess length of round U-bolts to after installation to prevent interference with leaf springs.

Repeat for opposite side.

10 ATTACH BRAKE/E-BRAKE LINE BRACKET

Attach the bracket removed in Step 4 to the air spring bracket using the M8 bolt (shown in Figure 10A).

Torque bolt to 19 ft-lbs (25 N•m).

Clip the ABS wiring loom into the slot on the relocation bracket (shown in Figure 10B).

Repeat for opposite side.

11 INSTALL HEAT SHIELD

Bend tabs on the heat shield so the required $\frac{1}{2}$ " of dead space exists between the heat shield and exhaust when attached.

Attach the heat shield to the exhaust pipe on passenger side using two ring clamps (shown in Figure 11 on the following page). Each hose clamp holds a tab against exhaust pipe.

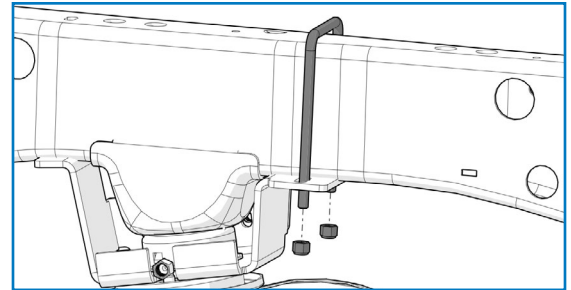

9A

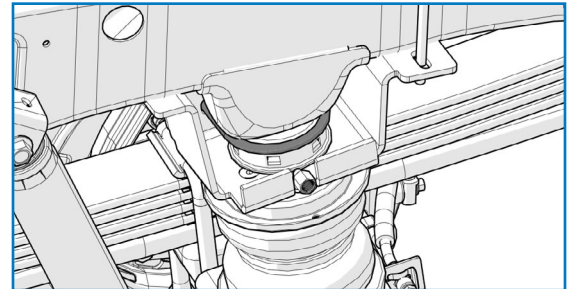

9B

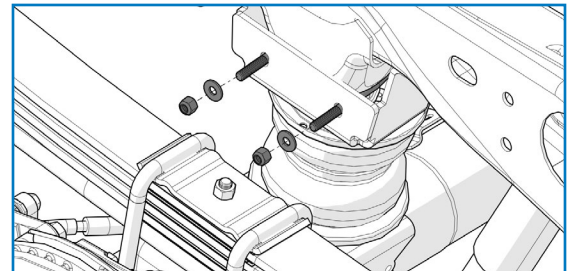

9C

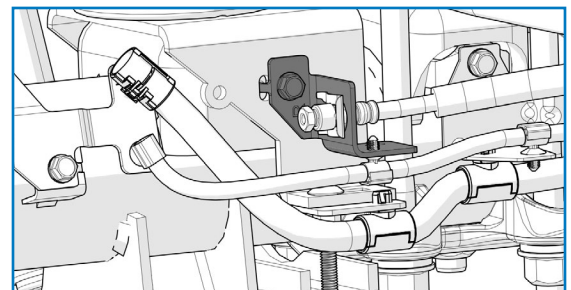

10A

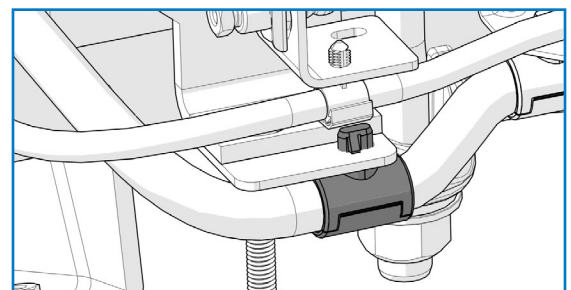

10B

12 INSTALL AIR LINE

PLEASE NOTE: This kit contains push-to-connect fittings; using scissors or wire cutters to cut the nylon airline will distort the line and cause the connection to leak. THE AIRLINE MUST BE CUT OFF SQUARELY WITH THE NYLON HOSE CUTTER PROVIDED IN THIS KIT OR A SHARP UTILITY KNIFE

Provided in air spring kit are two fill valves. The most common place to install is in place of license plate fasteners. Alternatively, two 5/16" holes can be drilled in a convenient location.

Cut air line assembly into two equal lengths with hose cutter.

Install one air line, route the nylon air line to an air spring fitting and cut the hose. Moisten the end of the air line prior to inserting it into the fitting and push it in until it stops. Repeat with the other fill valve.

Secure airlines using the tie-straps, away from moving items and heat sources.

Place a 5/16" nut on the air valve. Leave enough of the inflation valve in front of the nut to extend through the hole, install a flat washer, and 5/16" nut and cap (reference Figure 12 for assembly). There should be enough valve exposed after installation—approximately 1/2"—to easily apply a pressure gauge or an air chuck.

If an in-cab inflation kit is being installed, follow the instructions provided with that kit now.

13 CHECK SYSTEM FOR LEAKS

Inflate both air springs to 90 psi and then use a mixture of dish soap and water on all air line connections to detect any air leaks. Large, expanding bubbles indicate a leak (as shown in Figure 13). Repair as necessary and retest.

Inflate air springs to a predetermined value and on following day recheck pressure. If one or both of air springs have lost pressure, an air leak is present. Leak must be repaired, and then retested until no leaks exist.



11

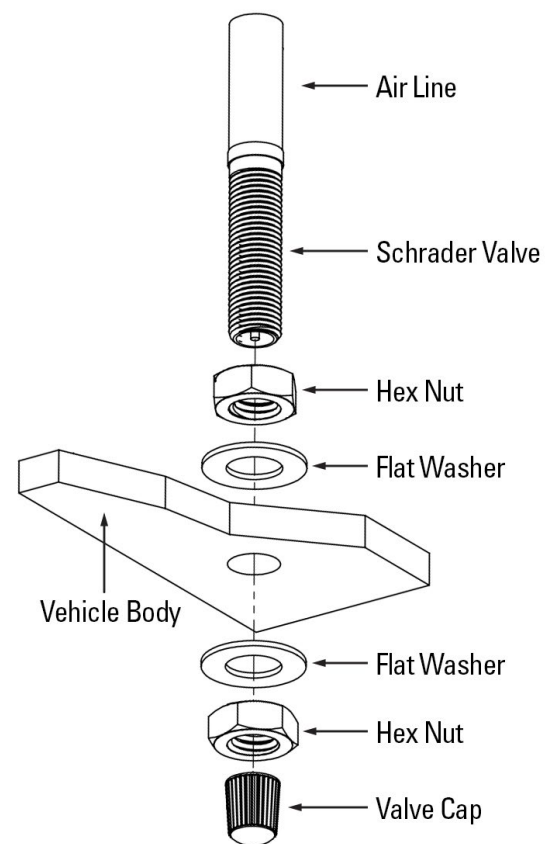

12

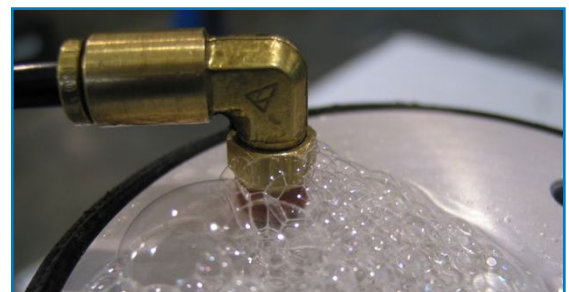

13

14 AFTER COMPLETING THE INSTALLATION

PLEASE REMEMBER:

Install wheels and torque fasteners to manufacturer's specifications.

Re-torque all fasteners after first 500 miles of driving.

For safe and proper operation, never operate the vehicle under minimum of 10 psi or over maximum of 100 psi in air springs.

Staying within pressure limit will ensure maximum air spring life. Failure in doing so may result in a void warranty (see **Note** below).

NOTE: Do not exceed maximum vehicle payload. Failure to do so may result in failure of the air suspension kit and/or damage to your vehicle.

.....

Thank you again, and congratulations on the installation of the air suspension kit.

OPTIONAL ACCESSORIES

Optional dual needle air gauges are available to monitor pressure in each spring from vehicle cab, as well as a full line of air compressors, air tanks, and solenoids built to work with and control your air spring system.

OPERATING YOUR VEHICLE WITH AIR SUSPENSION

Air springs have minimum and maximum pressure requirements. Never operate your vehicle with less than 10 psi in air spring and never inflate air springs over 100 psi. Damage to air springs will result.

Check air pressure in air springs daily for first couple of days to ensure a leak has not developed. Air springs are designed to maintain the vehicles stock ride height with a load. Do not use the air springs as a means to lift vehicle with no load. This will result in a harsh ride.

SERVICING YOUR VEHICLE WITH AIR SUSPENSION

When lifting the vehicle with a floor jack or hoist on the frame, never allow the air spring to limit the travel of the axle. Try to always jack the vehicle on the axle. Suspending the axle with the air spring limiting the axle travel will damage the air spring and void the air spring warranty.

WARRANTY

The owner's warranty will be void if air springs are run with less than the minimum of 10 psi. See additional warranty for details.

.....